



DBK17™

4-Channel Simultaneous Sample & Hold Card



Compatibility: ✓ LogBook ✓ DaqBook ✓ DaqLab ✓ DaqScan ✓ DaqBoard/2000 Series

See DBK45 for SS&H plus low-pass filter

Features

- Provides four input channels with simultaneous sample and hold
- Features a separate instrumentation amplifier and input stage for each channel
- One system accepts up to 64 DBK17 cards for a total of 256 simultaneously sampled inputs
- All channels sampled within 100 ns of one another

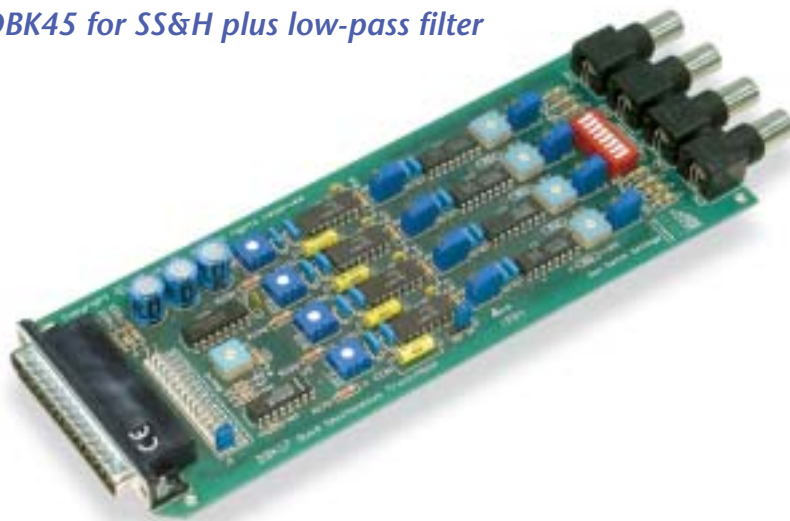

The DBK17™ simultaneous sample and hold* card allows IOtech's data acquisition systems to capture multiple input channels concurrently in order to eliminate channel-to-channel time skewing. Each DBK17 provides four channels of differential voltage input. The 16 analog input channels of the data acquisition systems can each accept up to four DBK17 cards, for a total of 256 analog input channels with simultaneous sampling. When multiple DBK17 cards are in use, all channels on all cards are sampled at the same instant.

Each of the DBK17's four channels features an instrumentation amplifier with switch-selectable gains of x1, 10, 100, 200, and 500. Each channel is also equipped with a location for a user-selected gain resistor, allowing you to select a custom gain up to x500. Each of the instrumentation amplifier input stages are followed by separate sample-and-hold stages whose outputs are connected to an output multiplexer stage. You can connect up to four DBK17s to one analog input channel.

The DBK17 is equipped with BNC input connectors. Its differential inputs are equipped with switchable 100K bias resistors referenced to analog common.

The DBK17 allows systems to capture multiple input channels simultaneously

DBK17 Simultaneous Sample & Hold Card Block Diagram

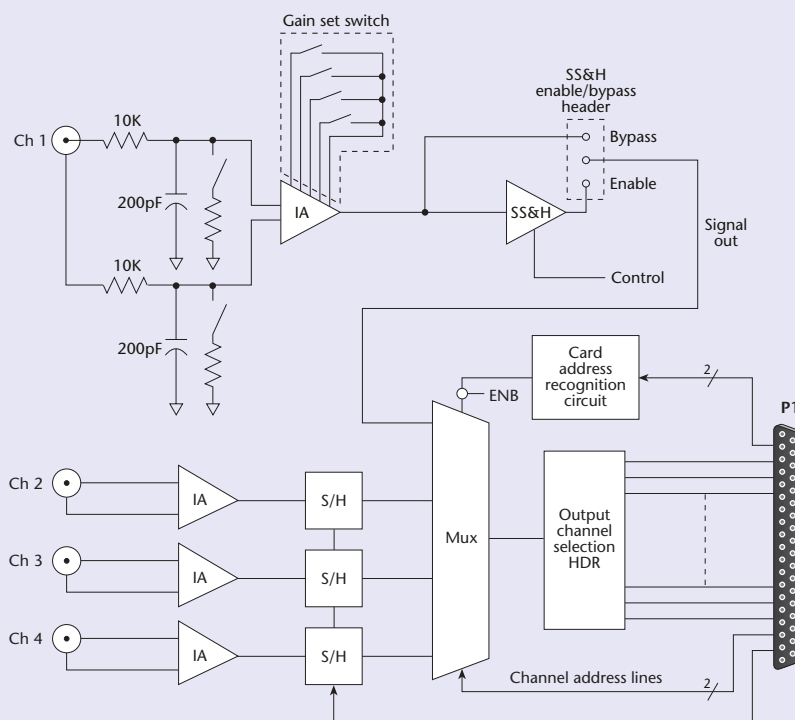

Note: Ch 1 is typical of Ch 2, Ch 3, and Ch 4

* In systems incorporating DBK products with SS&H, the per-channel rate is [Maximum sample rate/(n + 1)], where n=number of channels



DBK17™

Specifications & Ordering Information

Specifications

Connector: DB37 male, mates with P1*; BNC connectors provided for signal inputs

Number of Channels: 4

Number of Cards Addressable: 64

Input Type: Differential

Voltage Input Ranges:

0 to ±5 VDC

0 to ±500 mVDC

0 to ±25 mVDC

0 to ±10 mVDC

For Custom Gains:

$$R_{\text{user}} = \frac{40,000}{\text{Gain}-1} - 80 \quad (\text{Ohms})$$

Input Amplifier Slew Rate: 12 V/μs min

Acquisition Time: 0.6 μs (10V excursion to 0.1%);
0.7 μs (10V excursion to 0.01%)

Channel-to-Channel Aperture Uncertainty: 50 ns

Output Droop Rate: 0.1 μV/μs

Bandwidth: 72.4 kHz

Input Gains: x1, 10, 100, 200, 500, and user determined up to 500

Input Offset Voltage: [500 + 5000/G] μV max (nullable)

Input Offset Drift: [±5 + 100/G] μV/°C max

Input Bias Current: 100 pA max

Input Offset Current: 50 pA max

Input Impedance: 5 x 10¹² Ohms parallel with 6 pF

Switchable Bias Resistors: 100K each to analog common

Gain Errors:

x1 ±0.04% max

x10 ±0.1% max

x100 ±0.2% max

x200 ±0.4% max

x500 ±1.0% max

Gain vs. Temperature:

x1 ±20 ppm/°C max

x10 ±20 ppm/°C max

x100 ±40 ppm/°C max

x200 ±60 ppm/°C max

x500 ±100 ppm/°C max

Non-Linearity:

x1 ±0.015% FS max

x10 ±0.015% FS max

x100 ±0.025% FS max

x200 ±0.025% FS max

x500 ±0.045% FS max

Common-Mode Rejection:

x1 70 dB min

x10 87 dB min

x100 100 dB min

x200 100 dB min

x500 100 dB min

Note: For simultaneous sample and hold with anti-alias filter, see DBK45.

Power Consumption: 905 mW

Ordering Information

Description
4-channel simultaneous sample
and hold card

Part No.

DBK17

Cables

For use with DBK10, use CA-37-x ribbon cable, or contact factory of additional cabling options

For use with DBK60 or LogBook360, no cable is required (except from DBK60 or LogBook/360 to the A/D mainframe)

For use with no enclosure, use CA-37-x where x is the number of DBK devices attached

For use with DaqLab series (internal slots), use CA-255-2T with one board, or CA-37-2 for use with two DBK cards (or contact factory for additional cabling options)

For complete information on accessories and cables, visit www.iotech.com/acc

Related Products

LogBook	p. 75
DaqBook	p. 89
DaqLab	p. 103
DaqScan	p. 108
DBK10	p. 126
DBK41	p. 146
DBK45	p. 154
DBK60	p. 160
DaqBoard/2000 Series	p. 192

* Attachment to the DaqBoard/2000 series requires a DBK200, DBK201, DBK202, DBK203, DBK205, or DBK209 adapter